



# GrayDesk™

Model B2-C®  
*Acoustically Transparent Mastering Console*

[Buy now](#)

[Read More>>](#)

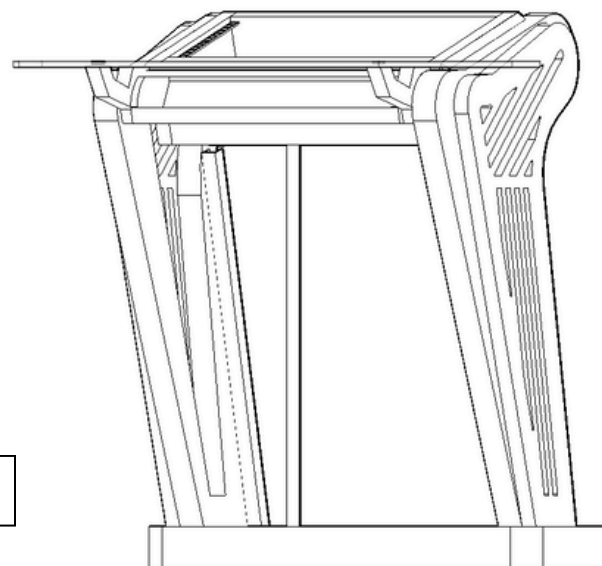

# Found you!

*Aren't you just as OCD as we are for that just '1 extra %' of sonic clarity?*

Designed to perform for the 'elite' niche of the pro audio industry, the 'C' variants are developed to fit in the tightest of studios!

- *~100% acoustical transparency*
- *Ultra-low profile footprint*
- *Ergonomical top-gear rack- 5RU!*
- *Cantilevering pedestal*
- *Intelligent Routing systems*

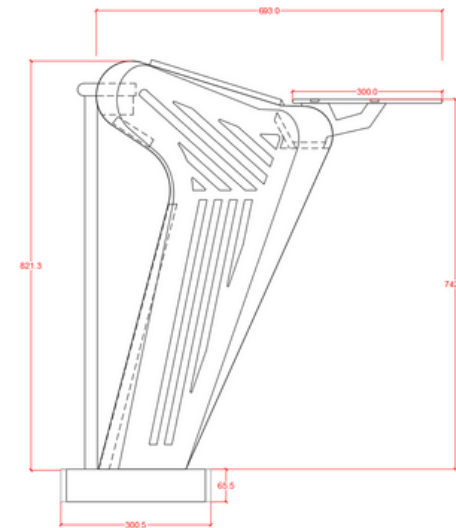
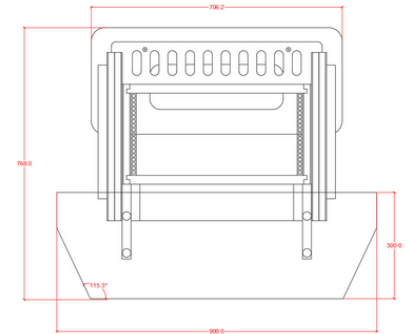



# Make it yours!

Pre-orders at 12 week dispatch time

- *Extend upto 7RU!*
- *Customizable peripheral shelf across glass, wood, epoxy and textile wrap!*
- *Customizable hardware mount for open storage and display mount*
- *Choose your hardwood accents!*
- *Choose your finishes!*
- *Add custom extensions!*

**Starts @ INR 1,20,000\***  
**~USD 1,381\***

GrayDesk™

Model B2-C ©

\*Prices are subject to change, and are ex-warehouse, exclusive of taxes, and logistics.

# What's the Buzz?

*Geeky much? Here's behind the scenes design:*

- *Low-footprint inherently reduces the acoustical footprint. Insignificant LF interaction.*
- *Geometrically planned to redirect the incident energy away from the listening area as much as possible (mostly mid-range).*
- *Utilising principles of wave diffraction, the surfaces are designed to let remaining energy 'wrap around' and pass through. While the lower frequencies do not see the smaller surfaces and naturally diffract around the console, the slotted design lets through the high mids and highs without any distortion, leaving an insignificant bandwidth of spectrum that negligibly interacts with the console.*
- *Holistically, the console is virtually invisible for speakers in reference to listening area.*



GrayDesk™

Model B2-C ©

